



**Solarbayer®**

*We develop for your future*

## PRODUCT INFORMATION

### STRATIFICATION BUFFER TANK SPS

Buffer tank for heating water with patented stratification system SLS®



## Technical Description

Content

Safety regulations . . . . . 3

Brief description . . . . . 4

Description of connections (without solar heat exchanger) . . . . . 5

Description of connections (option with one solar heat exchanger) . . . . . 6

Description of connections (option with two solar heat exchangers) . . . . . 7

Technical specifications . . . . . 8

Technical specifications, dimensions . . . . . 9

Installation / general information . . . . . 10

Connection example . . . . . 12

Insulation . . . . . 13

Installation of the insulation . . . . . 14

Trouble shooting . . . . . 17

Pictures and drawings in this product information are for information use only  
 and do not replace professional planning.  
 We assume no liability for completeness and accuracy  
 because of technical changes, typing and printing errors.

## Safety regulations

Please read the manual carefully to prevent damages due to improper installation. The installation has to be carried out by a specialized company in accordance with the „generally accepted codes of practice“ as well as with the valid regulations and norms. Country-specific regulations have to be regarded. Non-professional installation as well as other than the intended use will lead to the expiration of warranty.

**The following engineering rules have to be particularly regarded:**

**DIN 1988**

Codes of practice for drinking water systems

**DIN 4751**

Safety requirements for heating installations

**DIN 4753**

Water heaters and water heating installations for drinking water and service water; requirements, marking, equipment and testing

**DIN EN 12975**

Thermal solar systems and components

**DIN 4807**

Expansion vessels

**DIN EN 12828**

Heating systems in buildings - Design for water-based heating systems

**DIN 18380**

Systems for heating and central water heating

**DIN 18381**

Gas, water and sewage plumbing works inside of buildings

**VDI 2035**

Prevention of damage in water heating installations

**DIN 18382**

Electric Cable and Wiring Systems Inside Buildings

**VDE 0100**

Erection of power installations

**VDE 0105**

Operation of electrical installations

**VDE 0190**

Potential equalizing of electrical installations

\*Before the installation it has to be tested if the DHW installation, especially the connection to the public water supply, is carried out in accordance with DIN 1988 and if the, stated in part 8, prescribed maintenance had taken place.  
The operability of security-relevant units (e.g. pressure regulator) has to be checked in any case.

## Brief description

**Buffer tank for heating water with patented thermo-hydraulic stratification system SLS® in flow and return line, for perfect heat layering.**

**Either with or without heat exchanger, SPS 800 and 1000 also available with 2 heat exchangers.**

- ✓ connections arranged in 90° angle, possible installation in the corner
- ✓ perfectly suitable for solar systems and wood log boiler systems
- ✓ either with or without heat exchanger available
- ✓ suitable for installations according to the Tichelmann system up to 30000 Liter
- ✓ max. tank charging temperature 95°C
- ✓ high quality steel S235JR
- ✓ solid construction with overlap welding
- ✓ double welding at the straight bead
- ✓ flexible foam insulation WLG 0,039, insulation thickness approx. 100 mm, silver PVC jacket, fire protection class B2, optionally available as flame retardant fire protection insulation ISO-B1
- ✓ installation of an electric heating element possible

### Corrosion protection

The internal of the buffer tank is not corrosion-resistant since the tank is designed for the application in closed heating systems as buffer tank for heating water.

Description of connections (without solar heat exchanger)

**Attention: The heating system has to be filled in accordance with VDI 2035.**

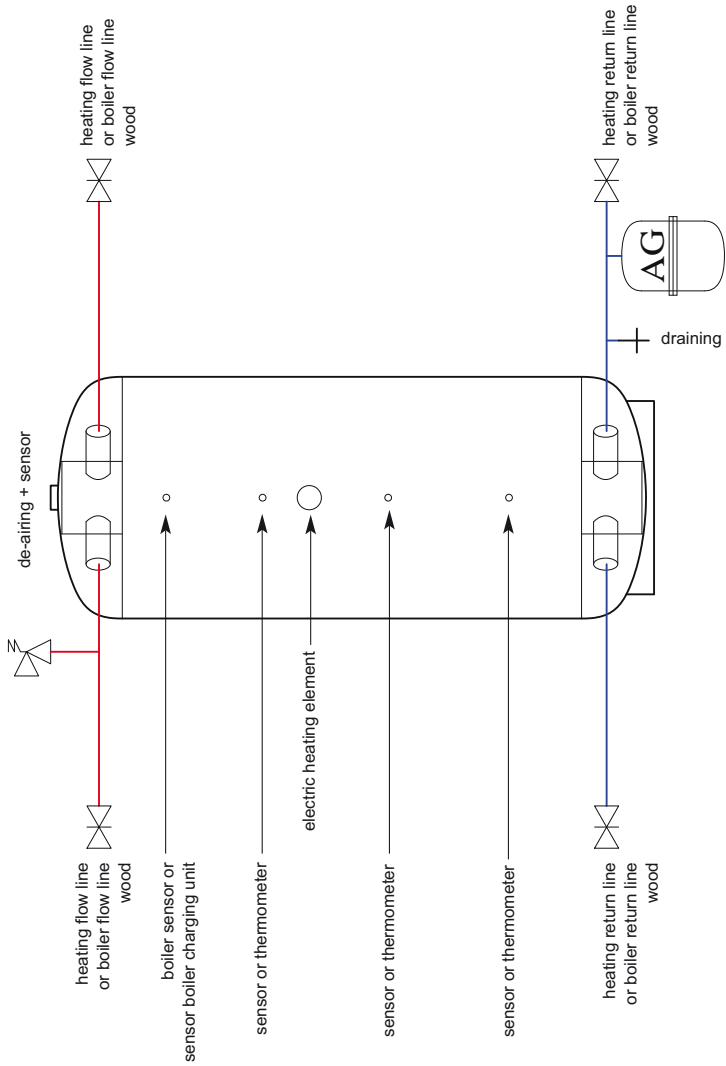

Description of connections (option with one solar heat exchanger)

**Attention: The heating system has to be filled in accordance with VDI 2035.**

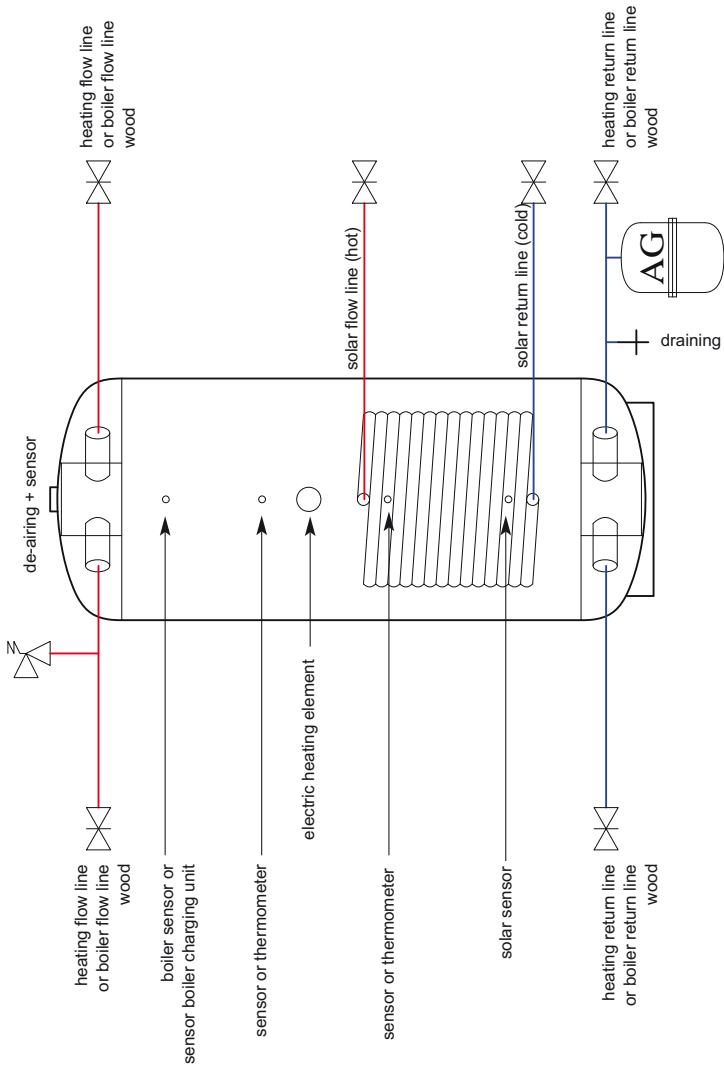

Description of connections (option with two solar heat exchangers)

**Attention: The heating system has to be filled in accordance with VDI 2035.**

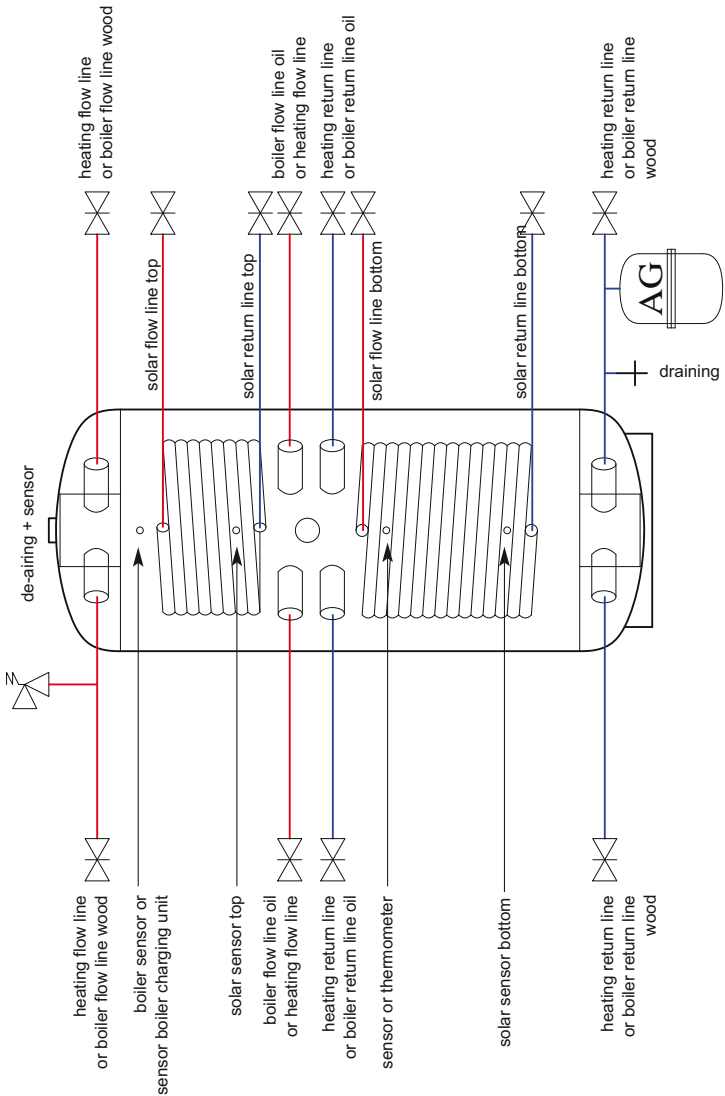

Technical specifications

Stratification buffer tank SPS			500	800	1000	1500	2200	2500	3000	5000
capacity approx.	L		500	800	1000	1500	2200	2500	3000	5000
height with insulation	[A]	mm	1720	1910	2090	2220	2170	2320	2770	2870
height without insulation	[B]	mm	1645	1835	2015	2145	2095	2245	2695	2795
tilted height		mm	1700	1950	2100	2250	2300	2450	2900	3100
diameter with insulation	[C]	mm	850	990	990	1200	1450	1450	1450	1800
diameter without insulation	[D]	mm	650	790	790	1000	1250	1250	1250	1600
flexible foam insulation (PVC jacket)		mm	100	100	100	100	100	100	100	100
weight approx. (without / with heat exchanger)		kg	73/98	115/139	130/160	193/221	258/309	273/325	335/400	625/710
max. operating temperature buffer tank		°C	95	95	95	95	95	95	95	95
max. operating pressure buffer tank		bar	6	6	6	6	6	6	6	6
SLS stratification system (top and bottom)		mm	∅ 200	∅ 200	∅ 200	∅ 200	∅ 300	∅ 300	∅ 300	∅ 300
max. size of electric heating element (optional)		kW	6	9	9	9	9	9	9	9
Specifications solar heat exchanger			500	800	1000	1500	2200	2500	3000	5000
heating surface heat exchanger top (optional)		m <sup>2</sup>	0,9	1,5	1,5	2,4	2,4	2,4	3,8	4,2
capacity heat exchanger top (optional)		L	5,5	7,3	7,3	13,5	13,5	13,5	17,6	20,5
heating surface heat ex. bottom (optional)		m <sup>2</sup>	3,0	3,5	4,0	4,5	5,0	5,0	5,0	5,0
capacity heat exchanger bottom (optional)		L	14,1	16,5	18,9	21,2	23,5	23,5	23,5	23,5
max. operating pressure heat exchanger		bar	10	10	10	10	10	10	10	10
max. operating temperature heat exchanger		°C	110	110	110	110	110	110	110	110
recommended min. collector surface		m <sup>2</sup>	10	14	17	23	31	34	38	50
Connections with dimensioning [version SPS]			500	800	1000	1500	2200	2500	3000	5000
de-airing	1½" IG [1]		oben	oben	oben	oben	oben	oben	oben	oben
sensor	½" IG [1a]		oben	oben	oben	oben	oben	oben	oben	oben
flow line boiler/heating	1½" IG* [2]	mm	1515	1690	1870	1935	1850	2000	2450	2480
flow line boiler/heating	1½" IG* [3]	mm	1515	1690	1870	1935	1850	2000	2450	2480
sensor/thermometer	½" IG [4]	mm	1420	1590	1770	1835	1845	1875	2325	2350
sensor/thermometer	½" IG [5]	mm	1120	1290	1370	1435	1545	1505	1825	1850
electric heating element	1½" IG [6]	mm	1000	1060	1140	1125	1175	1205	1415	1500
sensor/thermometer	½" IG [7]	mm	670	730	770	835	845	845	945	1070
sensor/thermometer	½" IG [8]	mm	340	370	370	435	545	545	545	570
return line boiler/heating	1½" IG* [9]	mm	140	170	170	235	320	320	320	340
return line boiler/heating	1½" IG* [10]	mm	140	170	170	235	320	320	320	340
Additional connections [version SPS/S]			500	800	1000	1500	2200	2500	3000	5000
flow line solar	1" IG [11]	mm	800	830	990	935	1045	1045	1195	1240
return line solar	1" IG [12]	mm	240	270	270	335	445	445	445	470
Additional connections [version SPS 2WT]			500	800	1000	1500	2200	2500	3000	5000
flow line solar	1" IG [13]	mm	1320	1440	1550	1735	1735	1775	2095	2220
return line solar	1" IG [14]	mm	1120	1160	1270	1345	1445	1335	1615	1660
flow line oil boiler or heating	1½" IG [15]	mm	900	930	1100	1075	1130	1130	1330	1410
flow line oil boiler or heating	1½" IG [16]	mm	900	930	1100	1075	1130	1130	1330	1410
return line oil boiler or heating	1½" IG [17]	mm	670	730	890	835	925	925	1075	1150
return line oil boiler or heating	1½" IG [18]	mm	670	730	890	835	925	925	1075	1150

\*from SPS 2200 on the connections are 2" internal thread



Technical specifications, dimensions

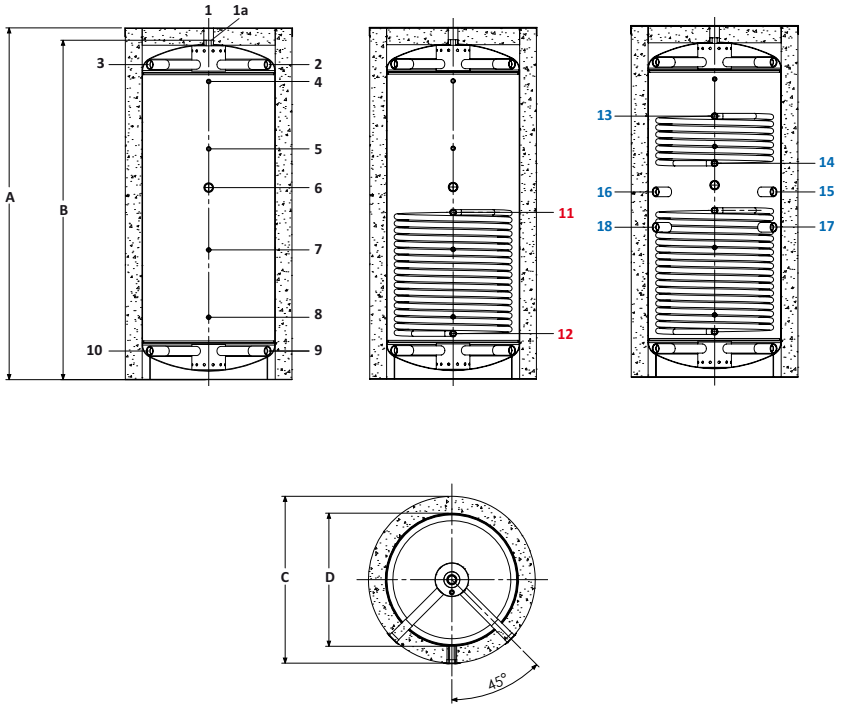

Thermotechnical specifications		500	800	1000	1500	2200	2500	3000	5000
heat loss in idleness according to DIN EN 12976 or DIN ENV 12977-3	W/K	1,50	1,99	2,18	2,88	3,45	3,70	4,44	5,80
heat loss on standby $\Delta T$ 45°C according to DIN 4753-8	kWh/d	1,62	2,15	2,36	3,11	3,73	3,99	4,80	6,27

## Installation / general information

### Location

The tank has to be located in a frost-protected place. Ice formation inside the system may lead to the tank's destruction.

The location has to have the necessary space for maintenance and repair work, as well as sufficient load-bearing capacity of the ground!

Site clearance for dismantling the tank and for transport has to be ensured permanently.

### Insulation

The insulation has to be mounted before piping begins.

**Do not get near the insulation with fire, brazing flame, welding torch, etc.; fire hazard!**

### Piping

The tank is to be installed in accordance with the piping diagram [chapter: Description of connections]. This diagram is only a mounting proposal and does not replace professional planning. The connection has to be carried out in accordance with DIN.

The minimum diameter of the safety valve has to be DN20 (¾").

Attention has to be paid to possible electro-chemical reactions when choosing the installation material (mixed installation)! Galvanized pipe installations have to be replaced.

**The connection components have to be aligned to these temperatures or the temperature has to be limited by means of a mixing valve!**

### Operating pressure

The permissible operating pressures according to our technical specifications [chapter: technical specifications] have to be observed. Exceeding the permissible operating pressure may lead to leakages and destruction of the tank!

### Safety devices

The tank has to be equipped with a non-lockable safety valve. Moreover, an expansion vessel has to be installed that is dimensioned according to the tank's capacity. It is to be locked only with a cap valve.

### Draining/de-airing

The tank has to be installed in such a way that it can be drained without demounting it.

**While draining, hot water might exit and cause injuries.**

The upper socket is provided for de-airing the tank.

We do not recommend the use of an automatic bleeder.

**Immersion heater (optional)**

The tank can additionally be equipped with an electric heating element. You have to respect the regulations of your local public utility when installing an immersion heater.

The electric heating elements have to be insulated. It is only with insulation that the corrosion protection is guaranteed.

Electric heating elements with insulation and integrated temperature control and safety temperature limiter are optional available at Solarbayer.

**If electric heating elements without insulation are used, the tank's warranty expires.**

**Initial operation**

Connections that are not used have to be sealed professionally with plugs.

**Thoroughly rinse pipes and tank after mounting, heating system has to be filled with treated water according to VDI 2035 and bled.**

**Note for installers:**

Record the pressure test and the proper filling of the heating system with water in accordance with VDI 2035 and let it countersign by your customer.

Connection example

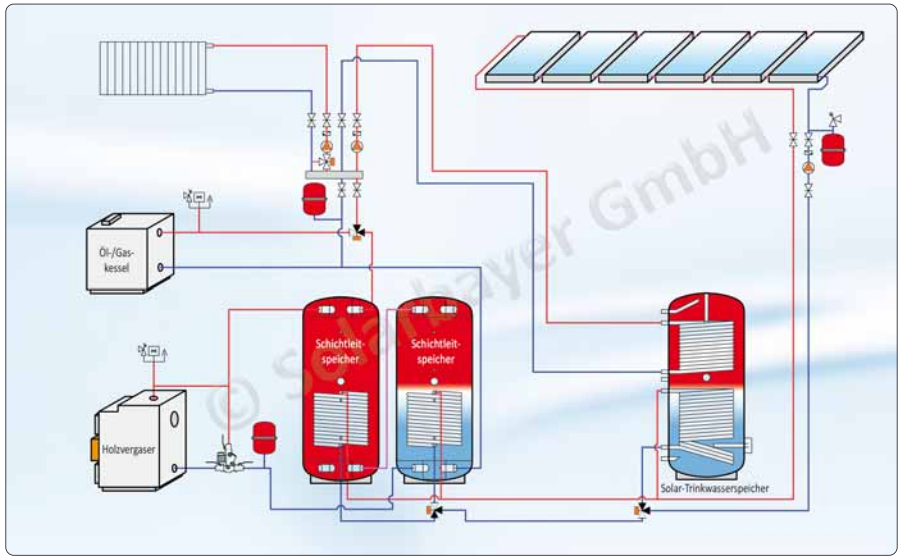

This connection diagram is only an installation proposal and does not replace technical planning!

You will find further examples for hydraulic connections in our brochure „Hydraulic diagrams” on our homepage:

<http://solarbayer.com/Heating-diagrams.html>

Insulation, technical facts

Types of insulation	Fire protection insulation ISO B1	Standard insulation B2
flexible foam insulation	100 mm	100 mm
outer jacket	PVC foil 0,55 mm + 5 mm flexible foam	PVC foil 0,8 mm + 5 mm flexible foam
jacket colour	grey	grey
proof of fire behaviour according to DIN 4102-1: 1998-05	fire classification B1	fire classification B2
lambda value (at 10°C ambient temperature)	0,039 W/mK	0,039 W/mK
closing of insulation jacket	stainless steel rail	zipper

**Inappropriate insulation of the tank's bottom is unacceptable.**

Tank sockets are available for all popular tank types up to 1000 Liter. You can increase the energetic efficiency with a perfect bottom insulation. Especially when renovating old buildings an additional insulation at the bottom is recommended. Our tank socket is an easy to realize alternative for this since it has excellent insulation characteristics.

Our tank sockets are made of galvanized steel and the rear side is insulated with flexible foam.

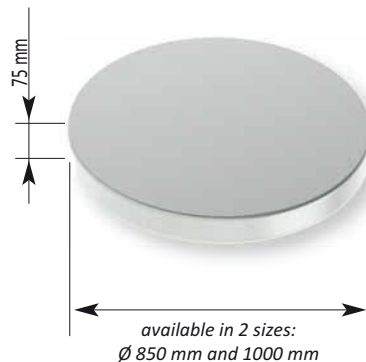

A: Installation of the fire protection insulation ISO B1 (when ordered)

**Notes for the installation of the fire protection insulation ISO B1:**

Only mount the insulation with a room temperature of at least 22°C!  
 Pre-heat the insulation in a heated room and mount in pre-heat condition!  
 The insulation material and the PVC jacket are too hard and too short when mounted in cold condition!



**1** Tilt buffer tank and place bottom insulation underneath the tank



**2** Pull the insulation ring for the tank's pedestal from top ...



...to bottom



**3** Put insulation around the tank and pass the sockets through the pre-cut holes (do not remove the foam plugs from the pre-cut holes that won't be used)



**4** Tightly enclose the tank with the insulation

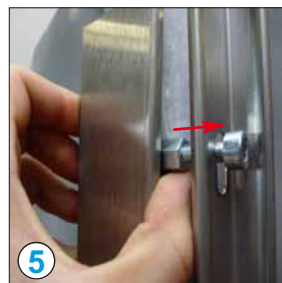

**5** Put the hexagon socket screws of the stainless steel rail from the left through the key seats of the right rail and click them into place (downwards).



**Only mount insulation when warm enough.**  
 Pre-heat for 24 hrs to at least 22 °C.



**6** Fasten all hexagon socket screws and check if the insulation jacket fits tightly.



**7** Put insulation on top of the tank (pay attention to the position of the sockets)



**8** Pull the black cap on top of the tank



**9** Feel for the sockets that are still underneath the PVC jacket



**10** Carefully cut out the holes



**11** Put on the collars and push them onto the sockets



**12** The tank is now ready to be connected!

We disclaim any liability for damages caused by inappropriate installation

*The displayed appearance of the tank may differ from yours (number of sockets/dimensions).*

**B: Installation of the standard insulation (fire protection class B2)**



*Only mount insulation when pre-heated.  
Pre-heat the insulation for at least 24 hrs to at least 22 °C.*



*Adjust sockets to insulation*



*Watch out when closing the zipper (danger of tearing the insulation when not warm enough)  
Do not use a tong or any other tool.*



*Feel for the sockets that are still underneath the PVC jacket*



*Carefully cut out the holes*



*Put on the collars and push them onto the sockets*



Trouble shooting

problem	possible reason	solution
leakage	leaky pipe connection	<ul style="list-style-type: none"> <li>• seal the connections</li> <li>• tighten pipe connections</li> </ul>
heating-up period too long	air in the system	<ul style="list-style-type: none"> <li>• de-air the system</li> </ul>
	heating temperature set too low with control unit	<ul style="list-style-type: none"> <li>• increase temperature setting with the control unit</li> </ul>
	scaled heat exchanger surfaces	<ul style="list-style-type: none"> <li>• run system with water treated in accordance with VDI 2035</li> </ul>
no/too small loading and unloading of the tank when heating is required (in the heating water circuit)	heating controller not set correctly	<ul style="list-style-type: none"> <li>• set controller</li> </ul>
	tank temperature too low	<ul style="list-style-type: none"> <li>• check heat sources (e.g. performance data)</li> </ul>
	changeover valve defect or installed incorrectly	<ul style="list-style-type: none"> <li>• check function</li> </ul>
	flow-rate is too low in the heating circuit	<ul style="list-style-type: none"> <li>• de-air heating circuit</li> <li>• increase pump performance</li> <li>• check pipe dimensions, if necessary adjust them</li> </ul>
unwanted tank cooling	gravity circulation in the solar/heating/circulation circuit	<ul style="list-style-type: none"> <li>• check/install gravity break</li> </ul>
	insufficient piping insulation	<ul style="list-style-type: none"> <li>• insulate piping/tank connections</li> </ul>
	insufficient tank insulation	<ul style="list-style-type: none"> <li>• mount Solarbayer tank insulation</li> </ul>



Notes





*We develop for your future*

Storage systems

Fresh water systems

Wood log boiler

Solar systems

**Solarbayer GmbH**

Preith, Am Dörrenhof 22

85131 Pollenfeld

Telefon +49(0)8421/93598-0

Telefax +49(0)8421/93598-29

[info@solarbayer.de](mailto:info@solarbayer.de)

[www.solarbayer.de](http://www.solarbayer.de)

This manual and the pictures and drawings within  
are protected by the copyright of SOLARBAYER GmbH.

Technical changes and errors reserved.

Valid is the most recent version of this handbook which can always be found on our homepage

[www.solarbayer.de](http://www.solarbayer.de)

This translation has been provided for informational use only.