



**Solarbayer®**

*We develop for your future*

## PRODUCT INFORMATION

### Hygienic stratification buffer tank HSK-SLS

Universal heat center for legionella-safe preparation of DHW



### Technical description

Content

Safety regulations . . . . . 3  
Brief description . . . . . 4  
Description of connections . . . . . 5  
Technical specifications . . . . . 6  
Technical facts, dimensions. . . . . 7  
Installation/general information. . . . . 8  
Connection example . . . . . 10  
Insulation . . . . . 11  
Installation of the insulation . . . . . 12  
Trouble shooting . . . . . 14

Pictures and drawings in this product information are for information use only  
and do not replace professional planning.  
We assume no liability for completeness and accuracy  
because of technical changes, typing and printing errors.

## Safety regulations

Please read the manual carefully to prevent damages due to improper installation. The installation has to be carried out by a specialized company in accordance with the „generally accepted codes of practice“ as well as with the valid regulations and norms. Country-specific regulations have to be regarded. Non-professional installation as well as other than the intended use will lead to the expiration of warranty.

The following engineering rules have to be particularly regarded:

**DIN 1988**

Codes of practice for drinking water systems

**DIN 4751**

Safety requirements for heating installations

**DIN 4753**

Water heaters and water heating installations for drinking water and service water; requirements, marking, equipment and testing

**DIN 4807**

Expansion vessels

**DIN EN 12828**

Heating systems in buildings - Design for water-based heating systems

**DIN 18380**

Systems for heating and central water heating

**DIN 18381**

Gas, water and sewage plumbing works inside of buildings

**VDI 2035**

Prevention of damage in water heating installations

**DIN 18382**

Electric Cable and Wiring Systems Inside Buildings

**VDE 0100**

Erection of power installations

**VDE 0105**

Operation of electrical installations

**VDE 0190**

Potential equalizing of electrical installations

\*Before the installation it has to be tested if the DHW installation, especially the connection to the public water supply, is carried out in accordance with DIN 1988 and if the, stated in part 8, prescribed maintenance had taken place.

The operability of security-relevant units (e.g. pressure regulator) has to be checked in any case.

## Brief description

**Universal heat center with integrated stainless steel corrugated tube for legionella-safe preparation of DHW, with large dimensioned oval tube heat exchangers. The area of application ranges from single-family houses to hotels and industrial buildings.**

- ✓ connections arranged in 90° angle, possible installation in the corner
- ✓ various connection possibilities
- ✓ perfect heat stratification due to the stratification pipe
- ✓ flexible foam insulation WLG 0,039, insulation thickness approx. 100 mm, silver PVC jacket, fire protection classification B2
- ✓ high quality steel S235JR
- ✓ large dimensioned solar oval tube heat exchanger, top and bottom
- ✓ legionella-safe DHW preparation
- ✓ stainless steel corrugated hose 1.4404 with DVGW authorization
- ✓ high hot water output
- ✓ installation of an electric heating element possible

### Corrosion protection

The stainless steel DHW exchanger (stainless steel corrugated tube) can be used with all DHW conditions and in every network. The corrosion protection is given by the stainless steel design.

The internal wall of the heating water tank is not corrosion protected since it is set for the application in closed heating systems as a buffer tank.

The application of the tank in pressureless heating circuits with Der Einsatz des Speichers in drucklosen Heizkreisen mit nachlaufendem Frischwasser ist nur zulässig, wenn Pufferspeicher und Holzkessel mittels Systemtrennung vom drucklosen/offenen Teil der Heizungsanlage getrennt ist.

Description of connections

**Attention:**  
The heating system has to be filled in accordance with VDI 2035.

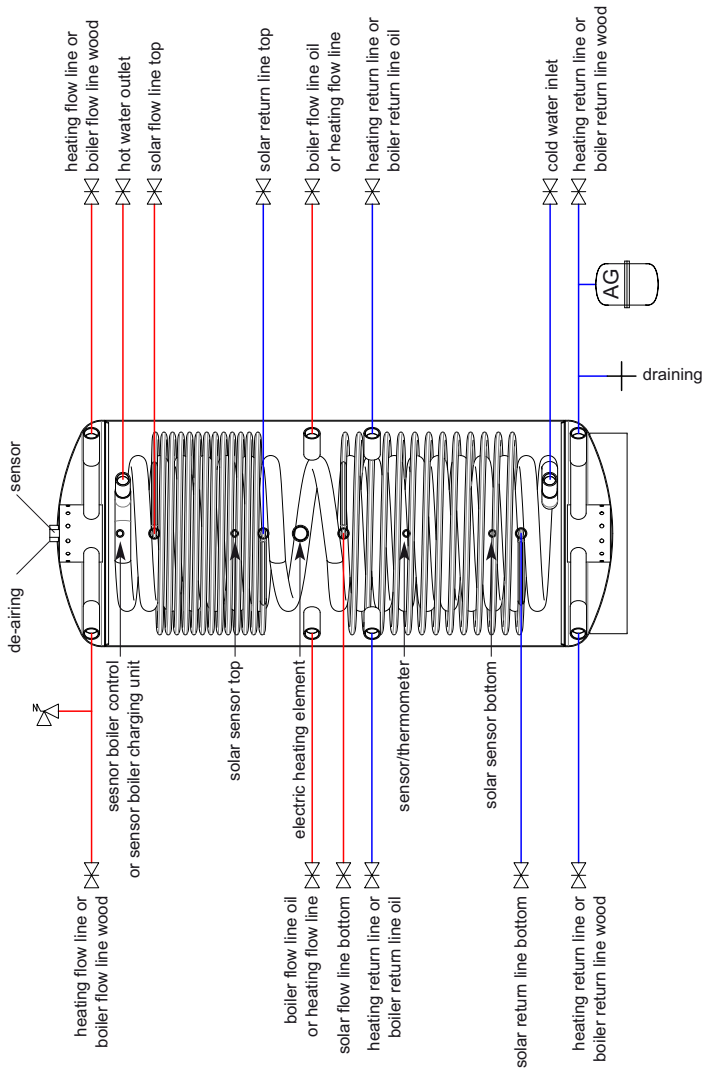

Technical specifications

Hygienic stratification buffer tank HSK-SLS			500	800	1000	1250	1500	2200
capacity approx.		L	500	800	1000	1250	1500	2200
height with insulation	[A]	mm	1720	1910	2090	2080	2220	2170
height without insulation	[B]	mm	1645	1835	2015	2005	2145	2095
tilted height		mm	1700	1950	2100	2130	2250	2300
diameter with insulation	[C]	mm	850	990	990	1100	1200	1450
diameter without insulation	[D]	mm	650	790	790	900	1000	1250
flexible foam insulation (PVC jacket)		mm	100	100	100	100	100	100
weight approx. (without / with heat exchanger)		kg	147	193	231	279	287	406
max. operating temperature heating water		bar	6	6	6	6	6	6
max. operating pressure heating water		°C	95	95	95	95	95	95
internal stratification system		mm	200	200	200	200	200	300
max. size of electric heating element (optional)		kW	4,5	6,0	6,0	6	9	9
specification stainless steel DHW heat exchanger			500	800	1000	1250	1500	2200
capacity DHW heat exchanger approx.		L	75	96	96	111	111	126
heating surface DHW heat exchanger approx.		m <sup>2</sup>	7,2	9,0	9,0	10,5	10,5	12
continuous output 10/45 at 17 kW, temperature buffer 65°C		L/h	480	510	510	522	522	540
continuous output 10/45 at 27 kW, temperature buffer 65°C		L/h	685	735	735	750	750	790
continuous output 10/45 at 50 kW, temperature buffer 65°C		L/h	1090	1345	1345	1380	1380	1465
stainless steel DHW heat exchanger		mm	∅ 48	∅ 48	∅ 48	∅ 48	∅ 48	∅ 48
max. operating pressure DHW heat exchanger		bar	6	6	6	6	6	6
max. operating temperature DHW heat exchanger		°C	95	95	95	95	95	95
specification solar heat exchanger			500	800	1000	1250	1500	2200
heating surface solar heat exchanger top		m <sup>2</sup>	1,3	2,0	3,0	3	3,5	4,2
capacity solar heat exchanger top		L	6,2	8,0	12,0	12,0	14	16,8
heating surface solar heat exchanger bottom		m <sup>2</sup>	2,3	3,0	3,0	3	3	5,5
capacity solar heat exchanger bottom		L	10,4	12,0	12,0	12,0	12,0	22,0
max. operating pressure solar heat exchanger		bar	10	10	10	10	10	10
max. operating temperature solar heat exchanger		°C	110	110	110	110	110	110
recommended min. collector surface		m <sup>2</sup>	10	14	17	20	23	31
Thermotechnical facts			500	800	1000	1250	1500	2200
rate of heat loss in stagnancy according to DIN EN 12976 or DIN ENV 12977-3		W/K	1,53	2,02	2,22	2,48	2,92	3,38
rate of standby loss ΔT 45°C according DIN 4753-8		kWh/d	2,22	2,94	3,23	3,61	4,25	4,93

Technical facts, dimensions

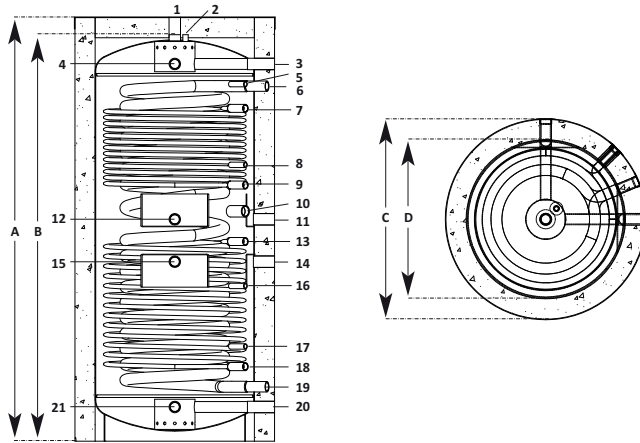

Anschlüsse mit Bemaßung				500	800	1000	1250	1500	2200
de-airing	1½"IG [1]	–	Oben	Oben	Oben	Oben	Oben	Oben	Oben
sensor	½"IG [2]	mm	Oben	Oben	Oben	Oben	Oben	Oben	Oben
inlet boiler/heating	1½"IG* [3]	mm	1510	1690	1870	1835	1935	1850	1850
inlet boiler/heating	1½"IG* [4]	mm	1510	1690	1870	1835	1935	1850	1850
sensor/thermometer	½"IG [5]	mm	1420	1590	1770	1735	1835	1845	1845
hot water	1¼"IG [6]	mm	1410	1580	1760	1725	1825	1835	1835
inlet solar exchanger top	1"IG [7]	mm	1320	1440	1650	1585	1735	1735	1735
sensor solar top	½"IG [8]	mm	1220	1290	1370	1405	1435	1445	1445
outlet solar exchanger top	1"IG [9]	mm	1120	1160	1270	1165	1235	1295	1295
electric heating element	1½"IG [10]	mm	1000	1060	1140	1045	1125	1175	1175
inlet boiler/heating	1½"IG [11]	mm	900	930	1100	885	1075	1130	1130
inlet boiler/heating	1½"IG [12]	mm	900	930	1100	885	1075	1130	1130
inlet solar exchanger bottom	1"IG [13]	mm	800	830	990	765	935	1045	1045
outlet boiler/heating	1½"IG [14]	mm	670	730	890	665	835	925	925
outlet boiler/heating	1½"IG [15]	mm	670	730	890	665	835	925	925
sensor/thermometer	½"IG [16]	mm	670	730	770	665	835	845	845
sensor solar bottom	½"IG [17]	mm	440	470	470	495	535	545	545
outlet solar exchanger bottom	1"IG [18]	mm	340	370	370	395	435	445	445
cold water	1¼"IG [19]	mm	240	270	270	295	335	335	335
outlet boiler/heating	1½"IG* [20]	mm	150	170	170	195	235	320	320
outlet boiler/heating	1½"IG* [21]	mm	150	170	170	195	235	320	320

\*from HSK-SLS 2200 on the connections are 2" IG (internal thread)

## Installation / Allgemeine Informationen

### Location

The tank has to be located in a frost-protected place. Ice formation inside the system may lead to the tank's destruction.

The location has to have the necessary space for maintenance and repair work, as well as sufficient load-bearing capacity of the ground!

Site clearance for dismantling the tank and for transport has to be ensured permanently.

### Insulation

The insulation has to be mounted before piping begins.

**Do not get near the insulation with fire, brazing flame, welding torch, etc.; fire hazard!**

### Piping

The tank is to be installed in accordance with the piping diagram [*chapter: Description of connections*]. This diagram is only a mounting proposal and does not replace professional planning. The connection has to be carried out in accordance with DIN. .

The minimum diameter of the safety valve has to be DN20 (¾").

Attention has to be paid to possible electro-chemical reactions when choosing the installation material (mixed installation)! Galvanized pipe installations have to be replaced.

With DHW temperatures of more than 60°C it is generally recommended to limit the temperature by a mixing valve to 60°C!

**The connection components have to be aligned to these temperatures or the temperature has to be limited by means of a mixing valve!**

### Operating pressure

The permissible operating pressures according to our technical specifications [*chapter: technical specifications*] have to be observed. Exceeding the permissible operating pressure may lead to leaks and destruction of the tank!

### Pressure-reducing valve

The installation of a pressure-reducing valve is recommended. If the DHW supply is operated with higher pressure a pressure reducing valve has to be installed.

In order to reduce sounds caused by fluxion inside the building the pipeline pressure should be adjusted to approx. 3,5 bar.

### DHW filter

It is highly recommended to install a DHW filter in the cold water pipeline since floating particles may block fittings, etc. and may cause corrosion in the pipes.



### Safety devices

The tank has to be equipped with a non-lockable safety valve. Moreover, an expansion vessel has to be installed that is dimensioned according to the tank's capacity. It is to be locked only with a cap valve.

An expansion vessel for sanitary water has to be installed for the stainless steel heat exchanger.

A safety temperature limiter has to be installed in accordance with heating system regulations for scalding protection means.

Next to the exhaust line of the safety valve, or even better, on the valve itself, an indication plate has to be installed, saying: :

**"Water is leaking from the valve's pipe for safety reasons during the heating. Do not close!"**

### Draining/de-airing

The tank has to be installed in such a way that it can be drained without demounting it.

**While draining, hot water might exit and cause injuries.**

The upper socket is provided for de-airing the tank.

We do not recommend the use of an automatic bleeder.

### Immersion heater (optional)

The tank can additionally be equipped with an electric heating element. You have to respect the regulations of your local public utility when installing an immersion heater.

The electric heating elements have to be insulated. It is only with insulation that the corrosion protection is guaranteed.

Electric heating elements with insulation and integrated temperature control and safety temperature limiter are optional available at Solarbayer.

**If electric heating elements without insulation are used, the tank's warranty expires. .**

### Initial operation

Connections that are not used have to be sealed professionally with plugs.

Thoroughly rinse pipes and tank after mounting, **heating system has to be filled with treated water according to VDI 2035** and bled.

### Not for installers :

Record the pressure test and the proper filling of the heating system with water in accordance with VDI 2035 and let it countersign by your customer.

Connection example

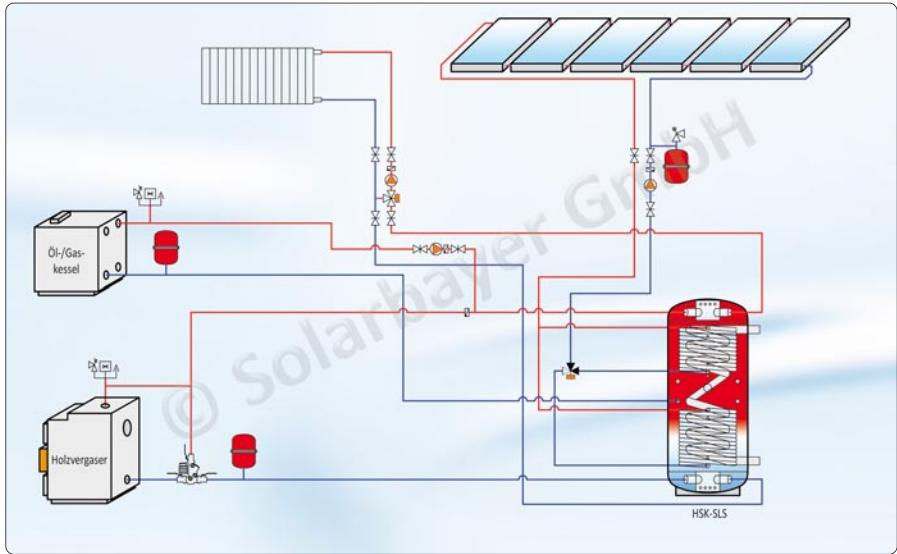

This connection diagram is only an installation proposal and does not replace technical planning!

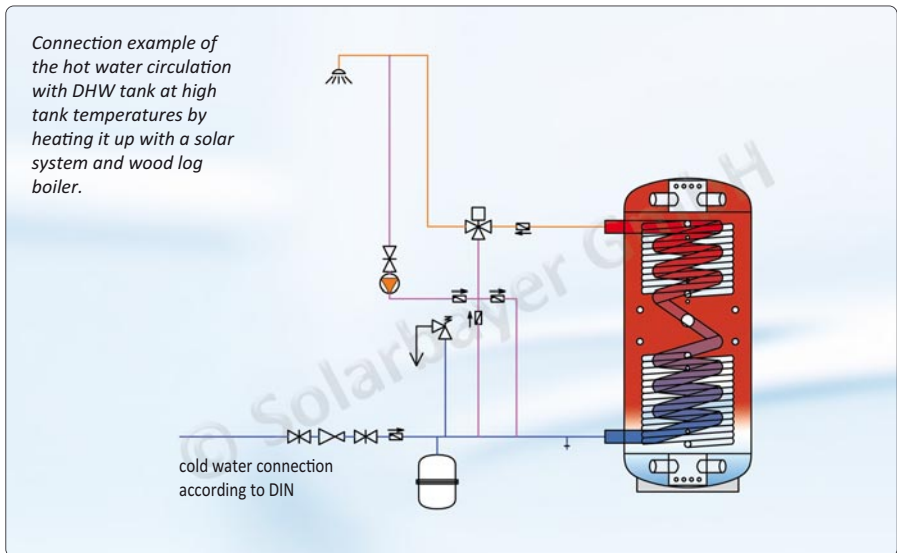

This connection diagram is only an installation proposal and does not replace technical planning!

## Insulation

flexible foam insulation		100 mm
jacket with zipper		PVC foil 0,8 mm + 5 mm flexibel foam
jacket color		Silber
foam density	kg/m <sup>3</sup>	14,1 (+/- 5% )
compressive resistance 40%	KPo	2,1 (+/- 5% )
initial heat conductivity	W/mK	0,039 (+/- 5% )
loss of density	%	5 Max
rebound elasticity	%	45 (+/- 5% )
porosity	N° Celle cml	17 (+/- 5% )
fire protection classification		B2

**Attention!** Only install the insulation with a room temperature of at least 22°C!  
Pre-heat the insulation several hours in a heated room and mount it when still heated!  
The flexible foam and the PVC jacket are too hard and too short when the insulation is cold!

Never use a tong or other tools in order to close the insulation!

Installation of the insulation



1

Delivery condition



2

Store single components in a warm room



3

Lift the tank of the pallet



4

Only mount insulation when pre-heated!  
Pre-heat it for 24 hours to at least of 22 °C.



5

Attach covering rosette



6

Watch out when closing the zipper (danger of tearing the insulation when cold)  
Do not use a tong or other tools.

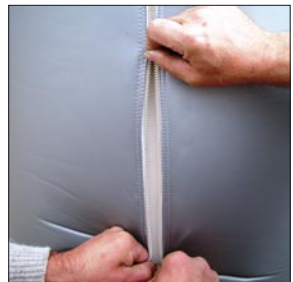
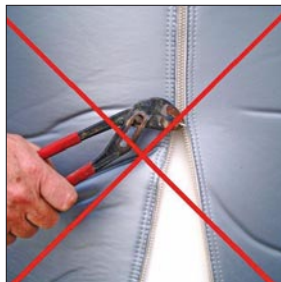



Put on the insulation cap and its cover

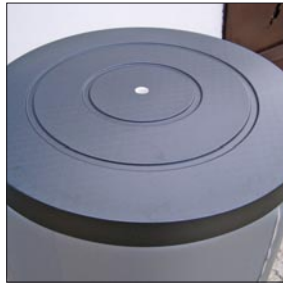

Feel for the sockets

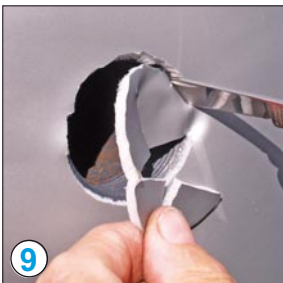

Löcher vorsichtig ausschneiden



Manschette aufsetzen und eindrücken

We disclaim any liability for damages due to inappropriate installation.

**Inappropriate insulation of the tank's bottom is not allowed.**

Tank sockets are available for the common tank sizes up to 1000 liter. You can increase the energetic efficiency with a perfect bottom insulation. Especially when renovating old buildings an additional bottom insulation is recommended. Our tank socket is an easy to realize alternative for this since it has excellent insulation characteristics.

Our tank sockets are made of galvanized steel and the rear side is insulated with rigid foam.

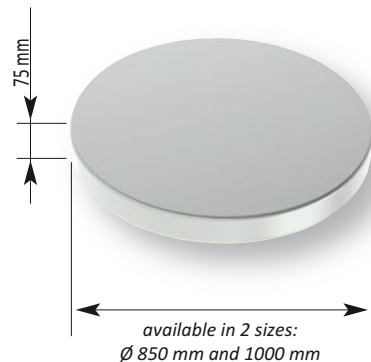

Trouble shooting

problem	possible reason	solution
leakage	leaky pipe connection	<ul style="list-style-type: none"> <li>• seal the connections</li> <li>• tighten pipe connections</li> </ul>
heating-up period too long	air in the system	<ul style="list-style-type: none"> <li>• bleed the system</li> </ul>
	heating water temperature set too low with control unit	<ul style="list-style-type: none"> <li>• increase temperature setting at the control unit</li> </ul>
	scaled heat exchanger surfaces	<ul style="list-style-type: none"> <li>• run system with water treated in accordance with VDI 2035</li> </ul>
no/too small loading and unloading of the tank when heating is required (in the heating water circuit)	heating controller not set correctly	<ul style="list-style-type: none"> <li>• set controller</li> </ul>
	tank temperature too low	<ul style="list-style-type: none"> <li>• check heat sources (e.g. performance data)</li> </ul>
	changeover valve defect or installed incorrectly	<ul style="list-style-type: none"> <li>• check function</li> </ul>
	flow-rate is too low in the heating circuit	<ul style="list-style-type: none"> <li>• bleed heating circuits</li> <li>• increase pump performance</li> <li>• check pipe dimensions, if necessary adjust them</li> </ul>
unwanted tank cooling	gravity circulation in the solar/heating/circulation circuit	<ul style="list-style-type: none"> <li>• check/install check valve with gravity break</li> </ul>
	pipng insulation not sufficient	<ul style="list-style-type: none"> <li>• insulate piping/tank connections</li> </ul>
	tank insulation not sufficient	<ul style="list-style-type: none"> <li>• mount Solarbayer tank insulation</li> </ul>
DHW temperature too low	safety temperature limiter set too low	<ul style="list-style-type: none"> <li>• increase temperature at the safety temperature limiter (thermostatic DHW mixing valve)</li> </ul>
	heating water temperature too low	<ul style="list-style-type: none"> <li>• place tank sensor correctly</li> <li>• increase tank temperature at the control unit</li> </ul>
	supplementary heating starts too late	<ul style="list-style-type: none"> <li>• check parameter of the heating controller (turn-on temperature difference)</li> </ul>

Notes

A large rectangular grid for taking notes. The grid consists of 20 columns and 30 rows of small squares. The lines are thin and gray, creating a uniform grid structure.



# Solarbayer®

*We develop for your future*

Storage systems

Fresh water systems

Wood log boiler

Solar systems

**Solarbayer GmbH**

Preith, Am Dörrenhof 22

85131 Pollenfeld

Telefon +49(0)8421/93598-0

Telefax +49(0)8421/93598-29

[info@solarbayer.de](mailto:info@solarbayer.de)

[www.solarbayer.de](http://www.solarbayer.de)

This manual and the pictures and drawings within are protected by the copyright of SOLARBAYER GmbH

Technical changes and errors reserved.

Valid is the most recent version of this handbool which can always be found on our homepage

[www.solarbayer.de](http://www.solarbayer.de)